

General information

Cavity

Type series: AV

Dimensions and sectional view

Beispiel für die Masseinheit:
Example for the dimensional units:
0.79 = 0.79 mm millimeter

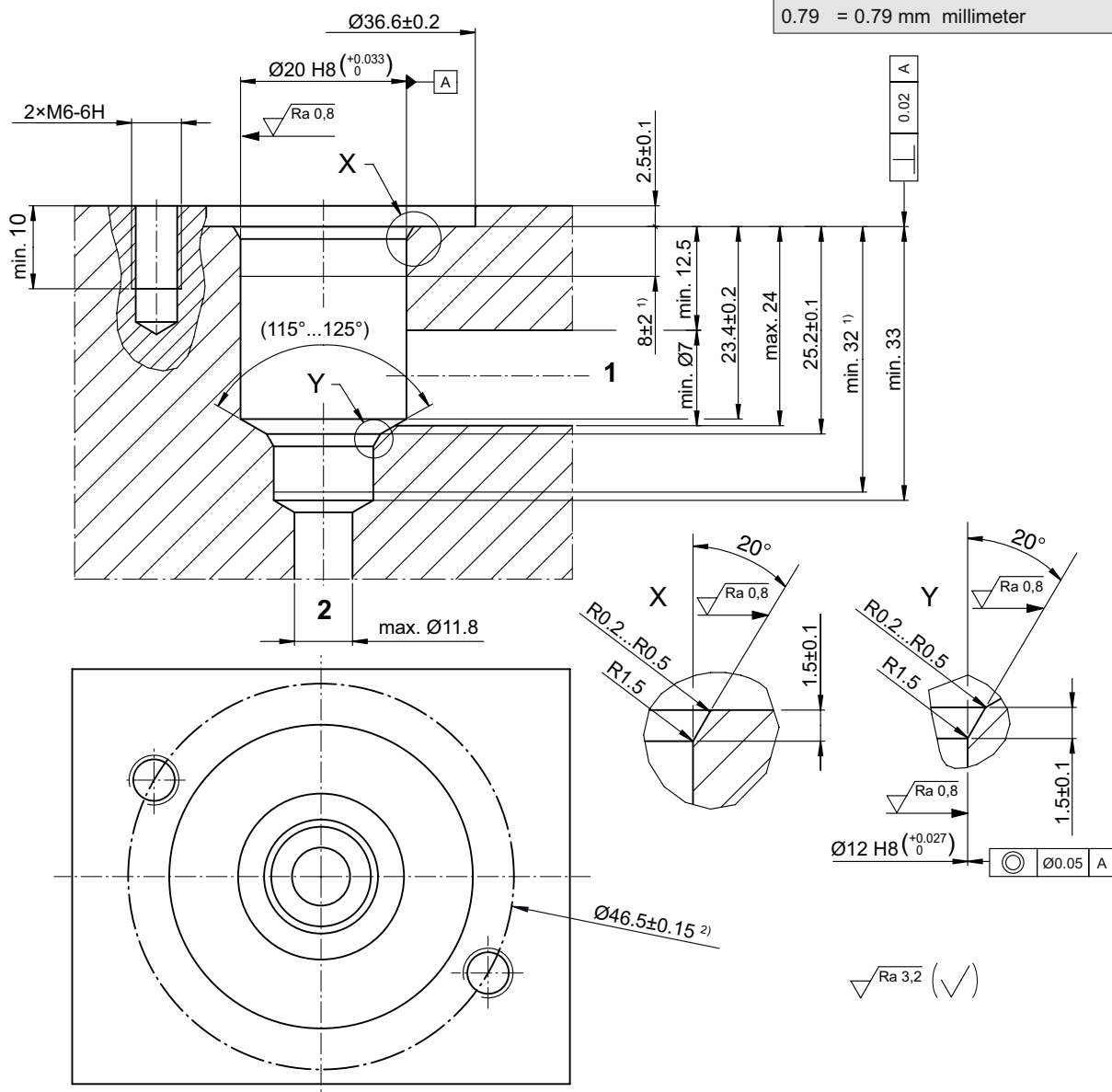

HINWEIS!
NOTE!

- 1) Passungstiefe
Minimum depth of specified diametral tolerance
- 2) Befestigungsbohrungen müssen immer im Winkel von 180° zueinander sein, können jedoch auf dem Teilkreis beliebig sein. Achtung: Befestigungsbohrungen dürfen Anschluss 1 nicht tangieren!
The mounting holes can be at any desired position but must be at 180° to each other on the PCD.
Note: they must not affect the 1 drilling!

Installation information



ATTENTION!

You must maintain the specified positional and diametral tolerances. To ensure trouble-free operation of the screw-in cartridges, we strongly recommend that pilot drilling, boring, reaming and cavity thread-cutting are always performed in one setup.



NOTE!

Cavity type to factory standard.



NOTE!

We offer form tool sets for sale or hire. For further information, see data sheet 400-P-040011.